



RELEASE EYEBOLTS
SECURING COVER
AND
SWING CUTTING
MECHANISM CLEAR
OF CASING
FOR INSPECTION
AND MAINTENANCE

MODEL 7A-6 **Hb** HEAVY DUTY

FREE DISCHARGE

SERIAL No. X

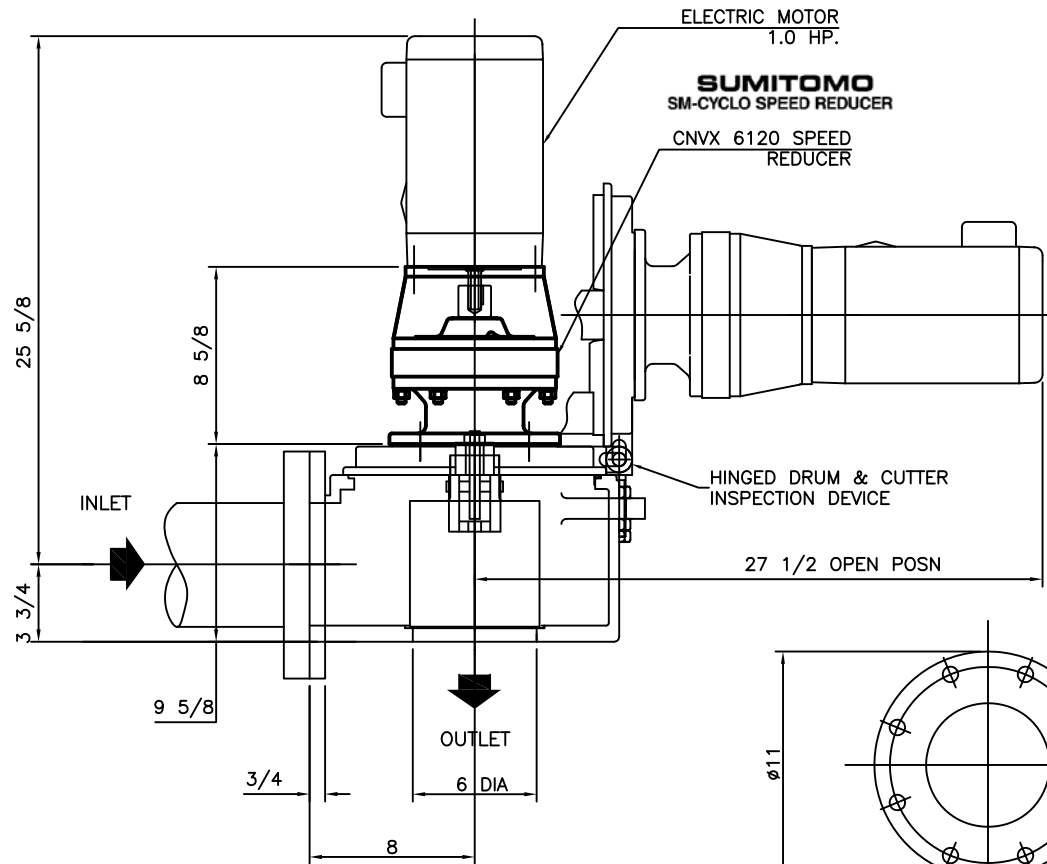

SIDE VIEW

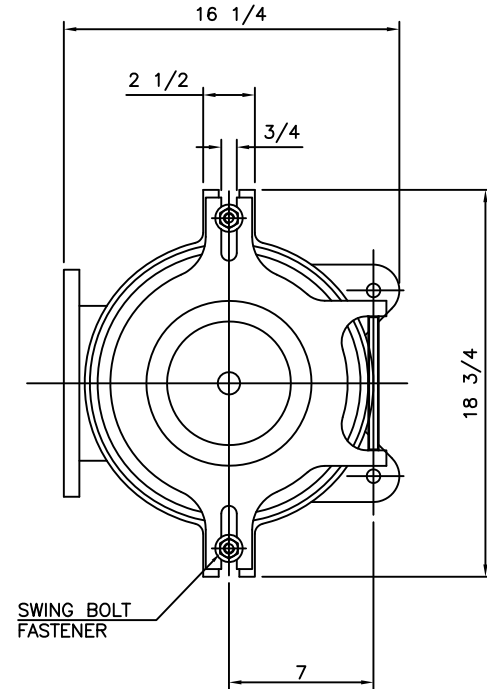

TOP VIEW

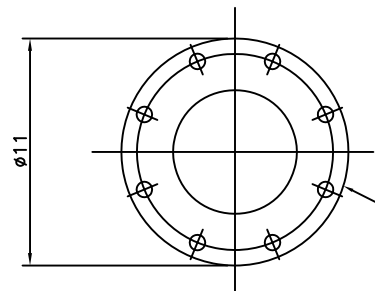

INLET FLANGE DETAIL

INLET FLANGE
6" 125 lb, 11" O.D., DRILLED
& TAPPED HOLES FOR 3/4"-10 UNC BOLTS,
8 No EQUI-SPACED ON 9.5" B.C.D.

MATERIALS OF CONSTRUCTION & GENERAL ENGINEERING DATA

HOUSING:	GREY IRON	CAPACITY	315 GPM (US) / 19.9 L/s	INLET AREA	34 SQ IN	219.4 cm sq							
DRUM (SCREEN):	DUCTILE IRON (ASTM 536 GRADE 60-45-18)	DRUM SPEED	50 RPM	OUTLET AREA	20 SQ IN	129 cm sq							
SHEAR BARS:	AISI-A2 HIGH ALLOY TOOL STEEL	ROTATION	C / CLOCKWISE	DRUM DIAMETER	6.5 IN	16.5 cm							
CUTTING BARS:	AISI-01 TOOL STEEL REVERSIBLE	SLOT WIDTH	.470 IN / 12 mm	WEIGHT	225 LB	102 kg							
HARDWARE & FASTENERS:	304 STAINLESS STEEL	No. OF SLOTS	20										
MOTOR MANUFACTURER:		POWER:	/ 3 / 60	RPM:	1750	REDUCER:	SM - CYCLO	MODEL:	V6120				
STYLE:	TEFC (IP55)	HP:	1.0	KW:	0.746	FRAME:	56C	FLANGE:	'C'	RATIO:	35:1	RATING:	4.27 HP

G.E.T. INDUSTRIES INC.
get@grindhog.com
www.grindhog.com
1 (877) 213-7418



<small>TOLERANCES</small>	INFO.	<small>SCALE</small>	NTS
<small>DECIMAL</small>	INFO.	<small>DRAWN BY</small>	G.P.
<small>FRACTIONAL</small>	INFO.	<small>APPROVED BY</small>	W.D.M.
<small>ANGULAR</small>	INFO.	<small>REV.</small>	
<small>DATE</small>	<small>FILE NO.</small>	<small>DWG. No.</small>	6 0052