

**MODEL 10 L**  
STANDARD COMMINUTOR  
SERIAL No. - \_\_\_\_\_

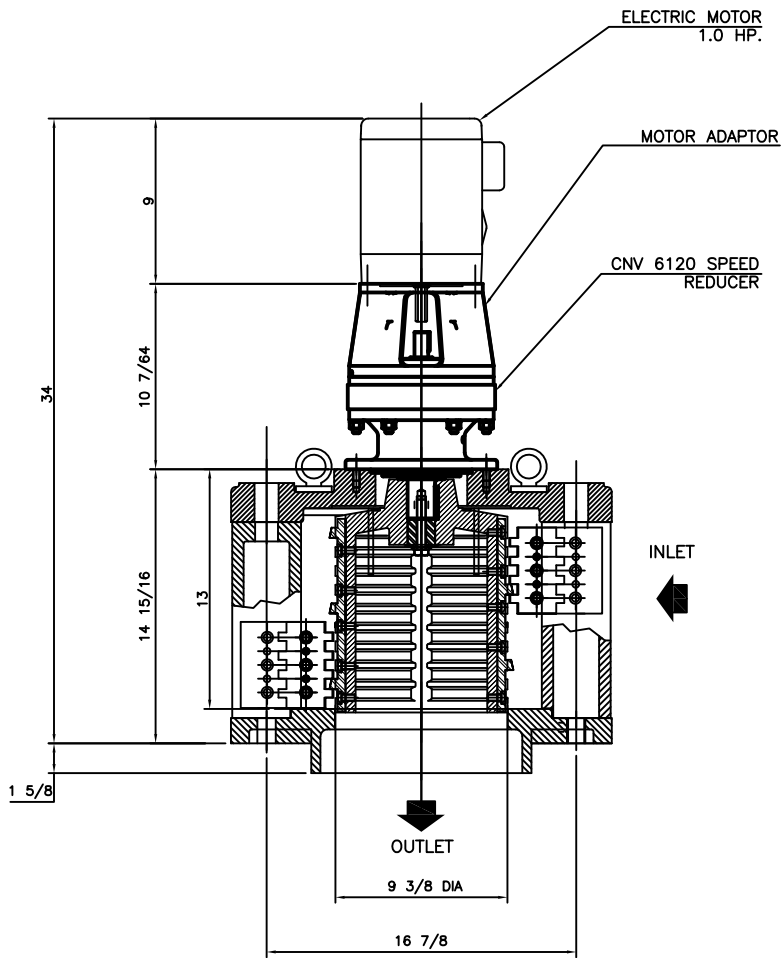

SIDE VIEW

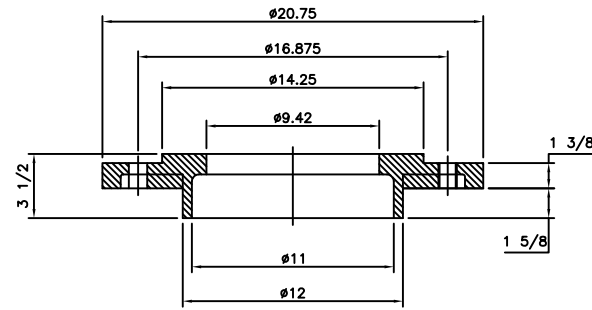

BASE RING DETAIL

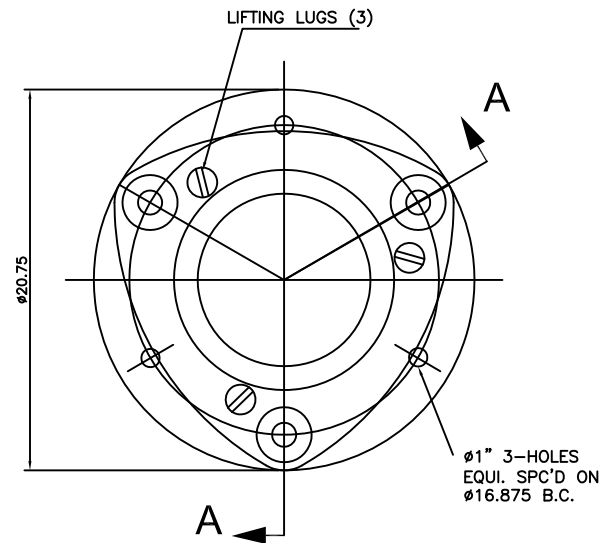

TOP VIEW  
COVER PLATE

**MATERIALS OF CONSTRUCTION & GENERAL ENGINEERING DATA**

HOUSING:	GREY IRON	CAPACITY	1.2 MGD (US) / 4500 m3/day	INLET AREA	97 SQ IN	626 cm sq
DRUM (SCREEN):	DUCTILE IRON (ASTM 536 GRADE 60-45-18)	DRUM SPEED	50 RPM	OUTLET AREA	45 SQ IN	290 cm sq
SHEAR BARS:	AISI-A2 HIGH ALLOY TOOL STEEL	ROTATION	CLOCKWISE	DRUM DIAMETER	9.4 IN	23.9 cm
CUTTING BARS:	AISI-01 TOOL STEEL REVERSIBLE	SLOT WIDTH	.470 IN / 12 mm	WEIGHT	400 LB	181 kg
HARDWARE & FASTENERS:	304 STAINLESS STEEL	No. OF SLOTS	36			
MOTOR MANUFACTURER:		POWER: -- / -- / --	RPM: 1750	REDUCER: SM - CYCLO	MODEL: V6120	
STYLE: TEFC	HP: 1.0	KW: 0.746	FRAME: 56C	FLANGE: 'C'	RATIO: 35:1	RATING: 4.27 HP

**G.E.T. INDUSTRIES INC.**  
get@grindhog.com  
www.grindhog.com  
1 (877) 213-7418

TOLERANCES	INFO	SCALE	NTS
DECIMAL		DRAWN BY	G.P.
FRACTIONAL		APPROVED BY	W.D.M.
ANGULAR		DATE	FILE NO.
			6 0170

# Grind Hog MODEL 10L (CAPACITY: 1.2 USMGD)

## REPLACEMENT OF JONES & ATTWOOD MODEL 10R

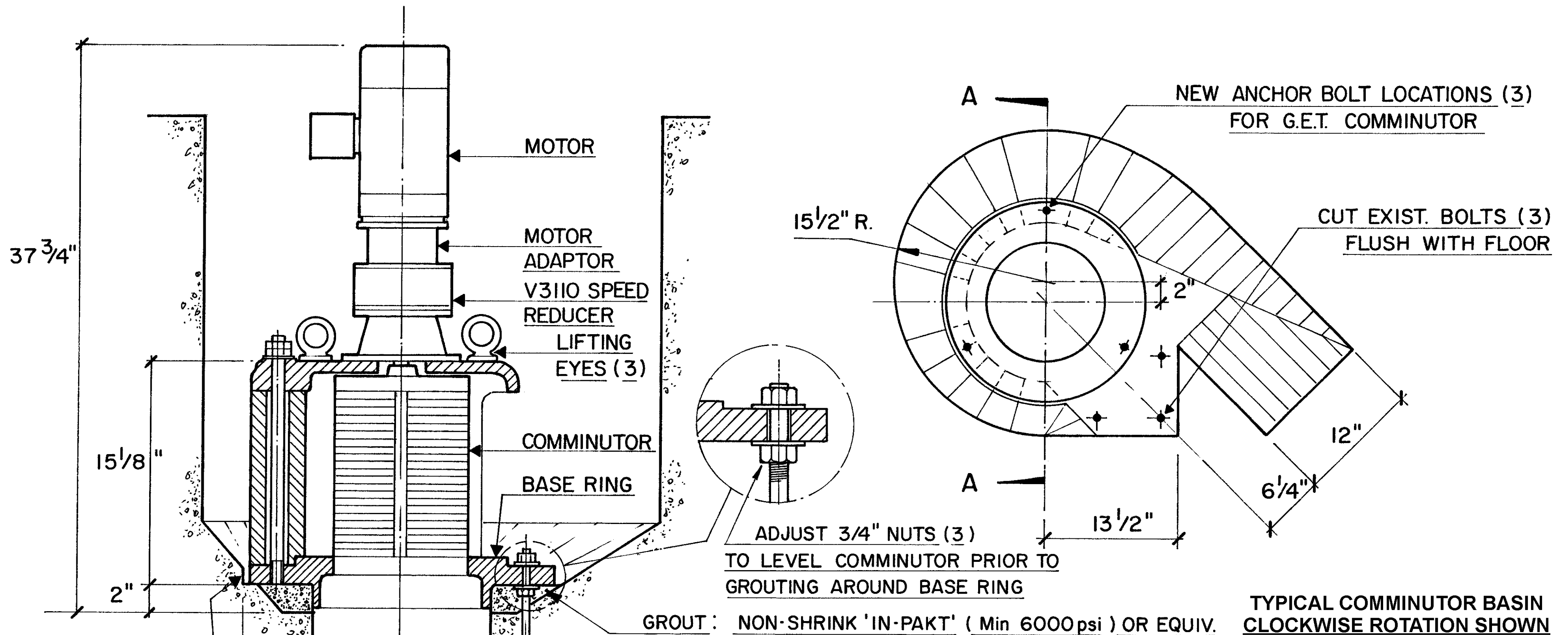

BEFORE LAYING GROUT REMOVE EXCESS CONC BENCHING, WHERE NECESSARY, TO ACCOMODATE COMM.

3/4" Ø x 15" LNG. 304 S.S. ADHESIVE ANCHOR BOLTS (3) (by others) EQUI-SPACED ON 16.875" B.C.D. MIN. 8" EMBEDMENT INTO EXIST. CONC.

### SECTION A-A

COMMUNUTOR WEIGHT :  
400 LB ( 181 KG)

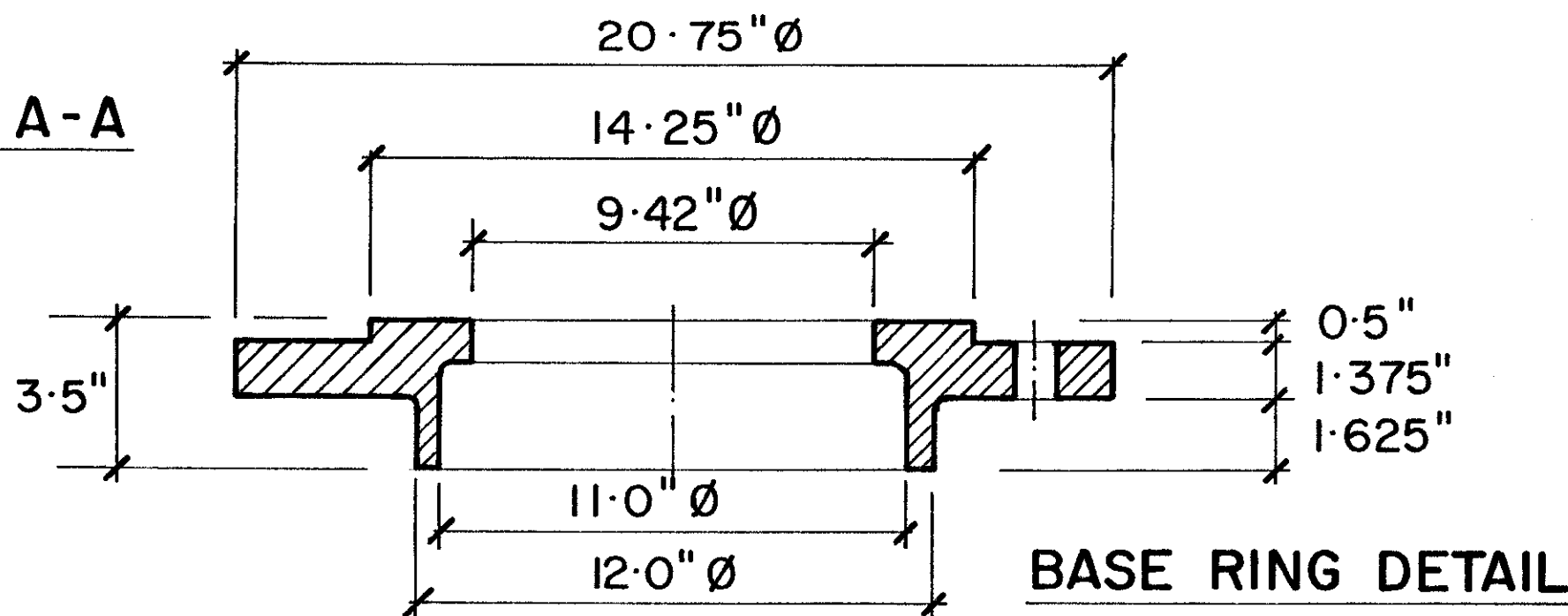

REVISIONS		BY	DATE	APP.
 <b>G.E.T. INDUSTRIES INC.</b> (877) 213-7418 www.grindhog.com				
TOLERANCES		SCALE		
±	DECIMAL	DRAWN BY		
±	FRACTIONAL			
±	ANGULAR			
±	DATE	PROJECT NO.	DRAWING NO.	REV.
			9 0065	