

**Grind Hog** <sup>T.M.</sup>

**KWIK-LIFT  
SLIDE RAIL  
REMOVAL SYSTEM**

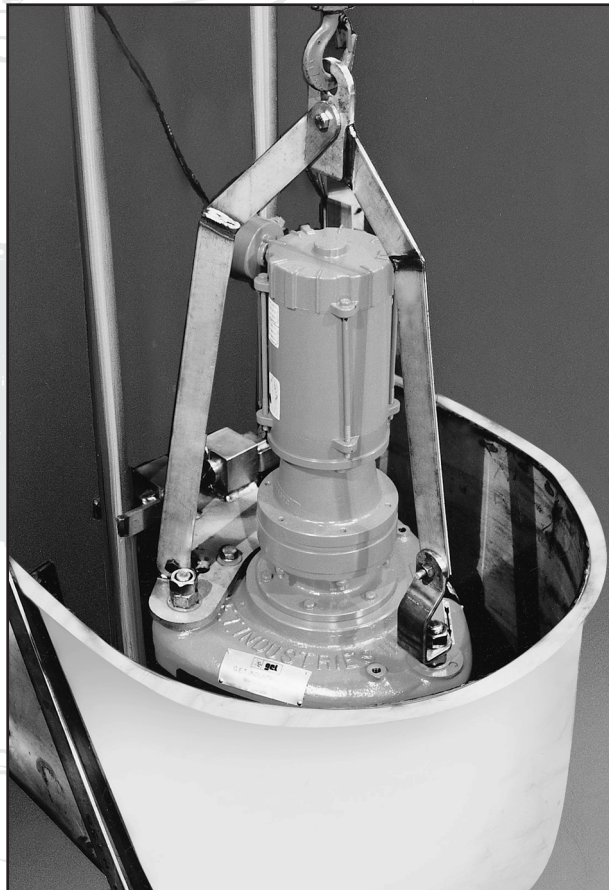

# KWIK-LIFT WET WELL REMOVAL SYSTEM

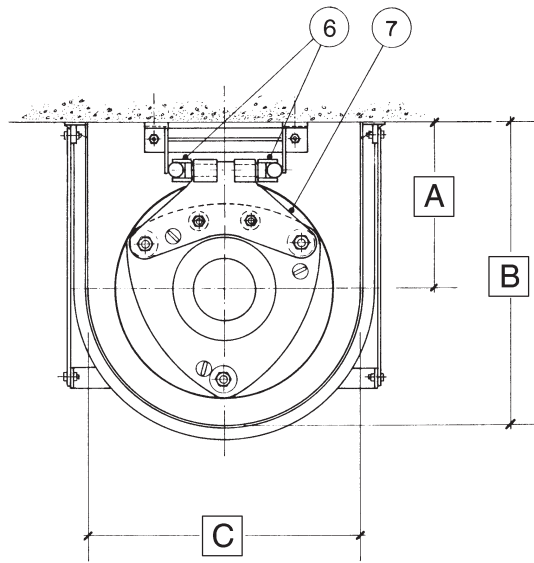

PLAN VIEW

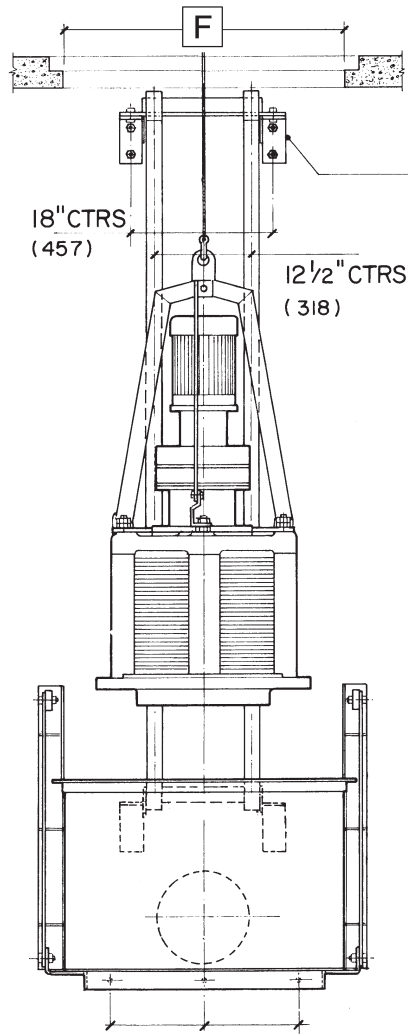

FRONT ELEVATION

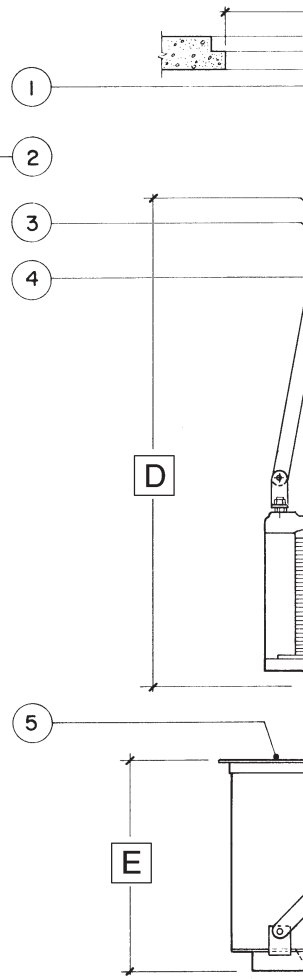

SIDE ELEV.

- ALL MATERIAL STAINLESS STEEL, EXCLUDING COMMINUTOR.
- IF DEPTH EXCEEDS 120" (3000mm) ADDITIONAL GUIDE RAIL SUPPORTS ARE REQUIRED.

## DIMENSIONAL DETAIL

MODEL	DIMENSIONS - IMPERIAL/METRIC														LIFTING WEIGHTS		CAPACITY RATINGS	
	DIM "A"		DIM "B"		DIM "C"		DIM "D"		DIM "E"		DIM "F"		DIM "G"					
	IN.	MM.	IN.	MM.	IN.	MM.	IN.	MM.	IN.	MM.	IN.	MM.	IN.	MM.	LBS.	KG.	MGD	M <sup>3</sup> /Day
10L	18	457	33	838	30	762	48	1219	15	381	30	762	12	304	500	227	1.2	4500
16A	21	534	39	990	36	915	64	1625	21	533	36	915	15	381	1000	454	3.5	13,200
16B	21	534	39	990	36	915	70	1778	26	660	36	915	15	381	1150	522	4.5	17,000
24A	25	635	47	1194	44	1118	80	2032	26	660	42	1066	19	482	1500	680	10	37,800
26A	<i>CONSULT FACTORY</i>														2750	1247	20	75,700

## KWIK-LIFT CHANNEL REMOVAL SYSTEM

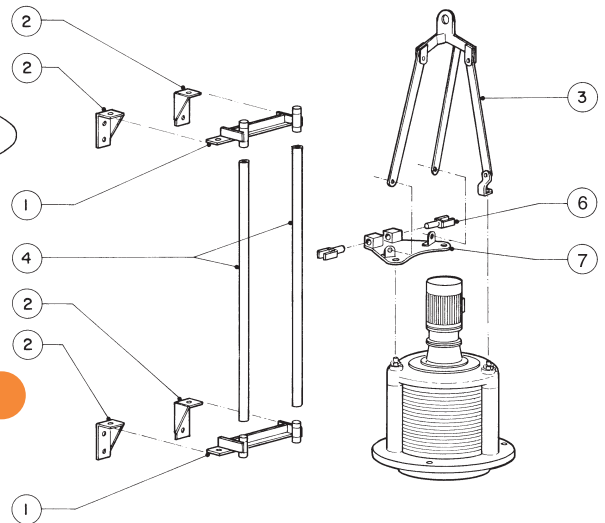
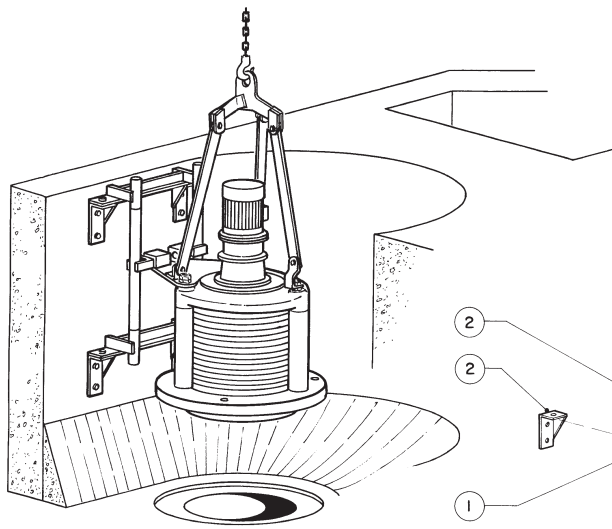
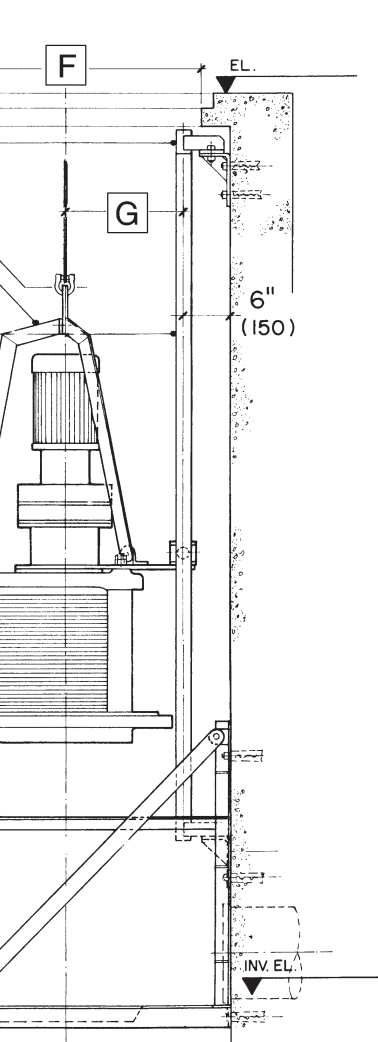

### SERVICE & MAINTENANCE

Remote removal system allows for a cleaner, safer working environment

### OPTIONAL WALL MOUNT BASIN

Optional well mounted basin for fiberglass or concrete lift stations

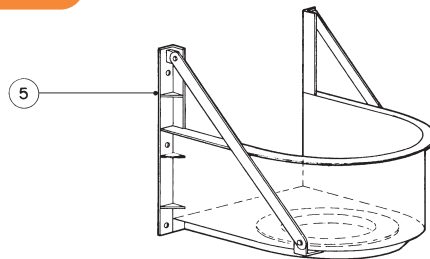

### COMPONENT LIST

ITEM	PART NO.	DESCRIPTION	MAT'L	QTY.
1	185243	GUIDE RAIL SUPPORT	S.S.	2 (MIN)*
2	185244	WALL MOUNTING BRACKET	S.S.	4 (MIN)
3	185245	LIFTING HARNESS	S.S.	1
4	185246	SLIDE RAIL	S.S.	2
5	185247	WET WELL BASIN	S.S.	1
6	185189	SLIDE RAIL GUIDE	S.S.	2
7	185252	COVER LIFTING PLATE	S.S.	1

### VARIABLES

- ELEVATIONS
- WET WELL WALL
  - FLAT
  - RADIUS \_\_\_\_\_
- HATCH LOCATION
- GUIDE RAIL SUPPORTS (QTY)

\* THIRD SUPPORT FOR RAILS OVER 10', FOURTH OVER 20' ETC.

VERTICAL DISCHARGE

**Grind Hog**<sup>TM</sup>  
**COMMINUTOR**

## ECONOMICAL RETROFIT ALTERNATIVES

- Convenience: ease of maintenance and repair with our Kwik-Lift Removal System
- Savings: avoid the expense of a major overhaul
- Prompt delivery from current production
- No structural changes to existing concrete basin required

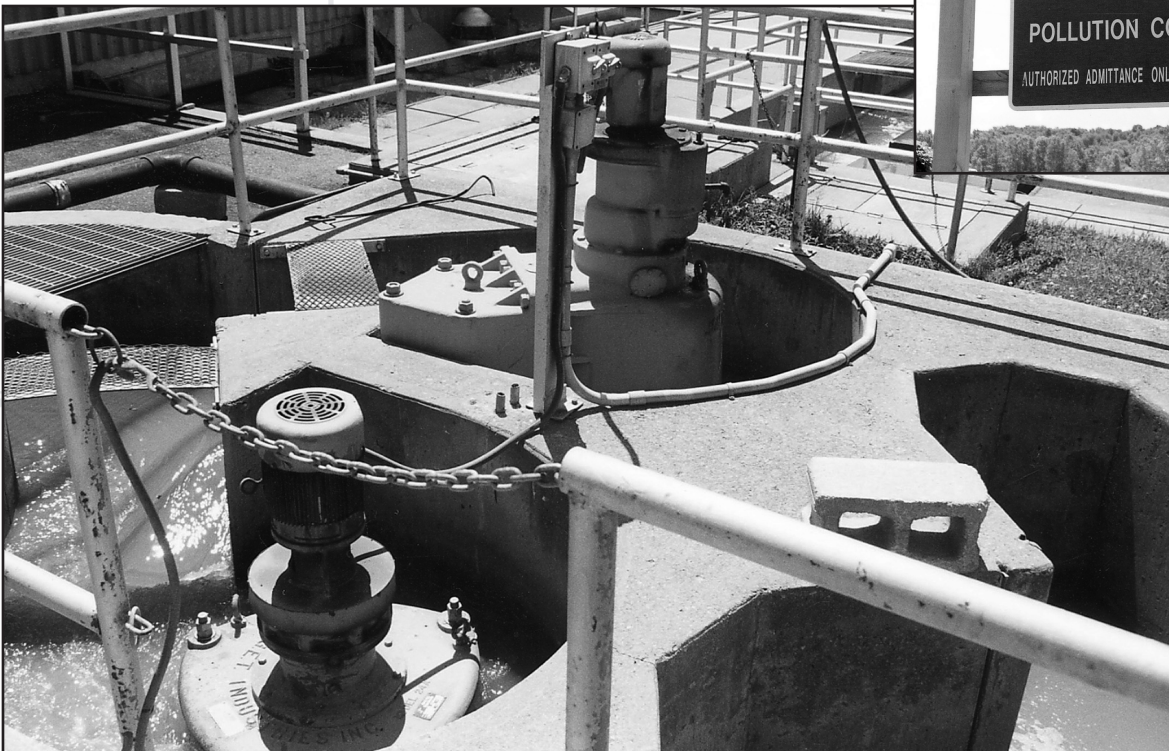

**BUILT TO LAST... ECONOMICALLY!**

**G.E.T. INDUSTRIES INC.**

represented by:



P.O. Box 640  
Brampton, Ontario  
Canada L6V 2L6  
Tel.: (905) 451-9900  
Fax: (905) 451-5376

[www.grindhog.com](http://www.grindhog.com) • e-mail: [get@grindhog.com](mailto:get@grindhog.com)