



MODEL 5AH **H_b** EAVY DUTY SPECIFICATION

1.0 General Specifications

There shall be furnished one (1) one only Grind Hog™ Model 5AH **HEAVY DUTY** Comminutor as manufactured by **G.E.T. Industries Inc.** with rotation in a counter-clockwise direction. The unit shall be driven by a remote hydraulic power unit

1.1 Design Criteria

The comminutor shall be designed to handle the flows indicated below, within the head loss noted.

- a) hydraulic capacity 130 GPM (8.2 l/s)
- b) satisfactory operation shall occur under conditions of zero flow
- c) head loss at peak flow shall not exceed 8 inches (203 mm)
- d) design shall be such that the flow enters the size reduction and screening device horizontally and exists vertically downward to facilitate the flushing of solids

1.2 Rotating Drum Screen

- a) heavy-duty Cast Ductile Iron ASTM 536, grade 60-45-18

1.3 Cutting Elements

- a) replaceable shear bars constructed of high-quality A2 tool-steel shall be attached to the rotating drum. Each shear bar shall be machined from solid bar stock, surface ground to establish exact tolerances
- b) stationary cutting bar shall be of high-quality 01 tool steel hardened to a minimum of 56 Rockwell C, and shall be reversible, allowing for four (4) sets of cutting edges prior to sharpening or replacement
- c) all submerged fasteners shall be of stainless steel

1.4 Flanged Body

- a) the body of the comminutor shall be of high quality cast iron and so designed to allow free unobstructed flow of influent through the unit. A Neoprene "O" Ring shall seal the chamber, allowing for operation under conditions of abnormally high head
- b) the inlet flange shall be 6" (152 mm)

1.5 Hydraulic Motor

The Grind Hog™ motor shall be a low speed, high torque, rotary power hydraulic motor that utilizes the hydraulic pressure developed by the hydraulic power unit to provide rotational torque for unit operation. Motor shall be water tight and functional when submerged up to 20 feet. Hydraulic motor shall be by Sauer Dan Foss or equal.

G.E.T. INDUSTRIES INC.

Toll Free: 877-213-7418 Email: get@grindhog.com Web: www.grindhog.com



1.6 Hydraulic Power Unit

a) General

1. The remotely located hydraulic power unit provides hydraulic oil power to drive the hydraulic motor which, through an SM-Cyclo Reducer, drives the rotating drum. In addition, the hydraulic power unit provides overload protection and quick response to frequent stop-start and severe reversing of the unit
2. The entire hydraulic system shall be designed to motor rated 2500-psi maximum pressure. At idle load conditions, the system operating pressure should be in the 200 to 400-psi range
3. As solids are encountered, oil pressure will automatically increase on a demand basis to provide the required hydraulic motor torque necessary to continue rotation of the drum screen
4. Should the system demand pressure exceed 1250-psi, a pressure switch shall be activated and a 4-way (2-directional) solenoid valve shifted. The rotation of the drum screen shall then reverse for about 5 seconds. At the end of this time, the valve shall again be shifted and the drum screen will return to the forward direction
5. If the obstruction has been cleared, the power pack unit shall continue to operate in the forward direction. If the obstruction has not cleared, the reversing sequence shall repeat until the torque requirement is reduced or until it has had to repeat the reversing cycle 7 times within a period of 45 seconds. If 7 reversals have occurred within 45 seconds the controller shall shut down the hydraulic unit, activate an overload relay, and illuminate the indicating light
6. If 5 occurs, contact Q8 for a possible auto-dialer is activated

b) Components

1. Hydraulic power unit shall include the following components at a minimum
 - a. MA 18 gallon, 24 1/2"x18 1/2"x14" Die Cast Aluminum Reservoir
 - b. Positive displacement pump driven by a TEFC, C face, vertically mounted 5 Hp motor (460/3/60)
 - c. Combination oil level and oil temperature gauge
 - d. 10-micron, oil return line filter
 - e. Oil temperature limit switch set at 176°F
 - f. Oil level switch
 - g. Filter breather
 - h. Pressure switch (adjustable) preset at 1250-psi
 - i. 110 volt solenoid valve
 - j. Relief valve preset at 1500-psi
 - k. 2-1/2 inch, 0 to 3000-psi oil filled gauge
 - l. Suction strainer
 - m. Flexible hoses rated for a minimum 2000-psi working pressure with quick disconnect at hydraulic motor end and at power pack end
2. The hydraulic power unit will be mounted in a remote location as specified by the owner

SPECIFICATION cont'd...



3. Hydraulic connections between the Grind Hog™ motor and the hydraulic power unit shall consist of two lengths of 1/2 inch flexible hose sections with quick disconnect couplers. Quick connections shall contain spring loaded ball check valves to avoid oil loss upon disconnecting
4. On completion of installation, the hydraulic power unit must be filled with a high quality fluid (supplied by others) with a viscosity of approximately 100 to 250-SSU at 100°F (38°C) with good chemical stability and anti-foaming properties. The grades of hydraulic fluid must be in accordance with the supplier's recommendations

CONTROL SYSTEM

a) Functional Description

1. The controller shall be the supplier's standard Model GHC 1850H with four (4) button remote control station (on, off, jog forward, jog reverse) and lights in NEMA 4X enclosure
2. The controller shall be equipped with a HAND-OFF/RESET-AUTO three-position selector switch. In OFF/RESET the unit shall not run. In HAND the grinder shall run. In AUTO the unit start and stop will be controlled by a remotely located dry contact
3. When a jam condition occurs in either the HAND or AUTO mode the controller shall stop the unit and reverse its rotation to clear the obstruction. If the jam is cleared, the controller shall return the unit to normal operation. If the jam condition still exists, the controller shall go through seven additional reversing cycles within 45 seconds before signaling an overload condition. When an overload condition occurs the controller shall shut the unit off and activate a fail relay with contacts
4. If operation is terminated due to a fail condition and a power failure occur, the fail indicator shall reactivate when power is restored
5. Controller reset shall be from local panel controls only
6. The controller shall provide over-current protection for the hydraulic power unit oil pump motor through an overload relay mounted directly on the motor starter
7. The controller shall have indicator lights for POWER ON, RUN, GRIND HOG™ OVERLOAD, MOTOR OVERLOAD, OIL OVERTEMP and LOW OIL LEVEL conditions
8. The controller shall be rated 5 Hp, ____ volts, ____ phase, ____ Hz

G.E.T. INDUSTRIES INC.

Toll Free: 877-213-7418 Email: get@grindhog.com Web: www.grindhog.com

SPECIFICATION cont'd...



b) Motor Controller Components

1. Enclosure:
 - a. Enclosure shall be fabricated of fiberglass reinforced polyester resins and shall be suitable for wall mounting. Doors shall have corrosion resistant hinges and latches
 - b. Each enclosure shall be NEMA 4X rated and house the overall disconnect switch, control power transformers, control devices, relays, fuses, terminal blocks and full voltage non-reversing motor starter
2. Control Devices:
 - a. Pilot devices shall be mounted on the enclosure front panel
 - b. Indicators shall be integral transformer type with low voltage long life 24 volt lamps. Lamps and selector switches shall be heavy duty NEMA 4X type
 - c. Two sets of normally open (no) dry contact shall be included, one for a FAIL signal output and one for a RUN signal output. The contacts shall be rated 10 amp, 240 VAC, resistive overload
3. Motor Starter:
 - a. A full voltage non-reversing contactor type motor starter shall be provided for the 5 Hp hydraulic oil pump electric motor
 - b. The overload (OL) relay shall be adjustable so that the range selected includes the FLA (Full load amps) rating and service factor

1.7 Drive Arrangement

- a) the hydraulic motor shall be close-coupled to a speed reducer drive, a heavy duty planetary gear of the totally enclosed non-vented type suitable for total submergence during emergencies
- b) double seals on the output shaft shall ensure flood-proof operation through a reduction ratio of 35:1
- c) the cycloidal reducer shall be capable of withstanding shock loads to 500% of its mechanical rating of 4.27 Hp. and be warranted for two (2) years
- d) the drive shall have a minimum full load efficiency of 90% and be pre-lubricated with grease, requiring routing maintenance every 500 to 1,000 hours

OPTIONAL INSTALLATION ARRANGEMENTS

A) Auto-Coupling Slide Rail System - Wet Well

- a) each Grind Hog™ shall be equipped with a Slide Rail System allowing for removal without entering the wet well
- b) a stationary PVC Overflow Coupling Box shall be flange mounted to the gravity sewer pipe as shown on the drawings. An open top will allow for overflow in the event of a disruption in service
- c) Wall Mounted Support Brackets shall be 304 stainless steel and shall be attached to the wet well wall
- d) Guide Rails shall be of 304 stainless steel pipe, 1.5" in diameter, and shall be of adequate length as shown on the drawings
- e) all anchorage hardware shall be of stainless steel, supplied by the contractor

G.E.T. INDUSTRIES INC.

Toll Free: 877-213-7418 Email: get@grindhog.com Web: www.grindhog.com

SPECIFICATION cont'd...



B) Auto-Coupling Slide Rail System - Chamber

- a) each Grind Hog™ shall be equipped with a Slide Rail System allowing for removal without entering the manhole
- b) a stationary PVC Overflow Coupling Box shall be flange mounted to the gravity sewer pipe as shown on the drawings. An open top will allow for overflow in the event of a disruption in service

.... alternatively....

a stationary galvanized steel Overflow Bar Screen and influent trough shall be mounted under the gravity sewer pipe as shown on the drawing. Stainless steel support brackets and hardware shall be provided

- c) supports brackets shall be of stainless steel and shall be mounted to the:
 - * Manhole Wall - PVC Overflow option
 - * Manhole Floor - Overflow Bar Screen Option
- d) Guide Rail Supports shall be 304 stainless steel pipe. 1.5" diameter, and of adequate length as shown on the drawing
- e) all anchorage hardware shall be of stainless steel, supplied by the contractor

C) Trash Basket - Optional

- a) a Trash Basket compatible with the Slide Rail System shall be provided, allowing for continued screening during comminutor maintenance.
Materials of construction are:
 - * 10 Gauge Aluminum
 - * 2" (51 mm) holes on 3" (76 mm) centers

G.E.T. INDUSTRIES INC.

Toll Free: 877-213-7418 Email: get@grindhog.com Web: www.grindhog.com

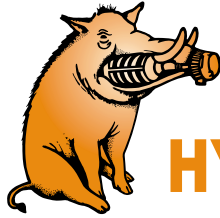

Grind Hog™

HYDRAULIC DATA SHEET PIPE MOUNTED MODEL 5

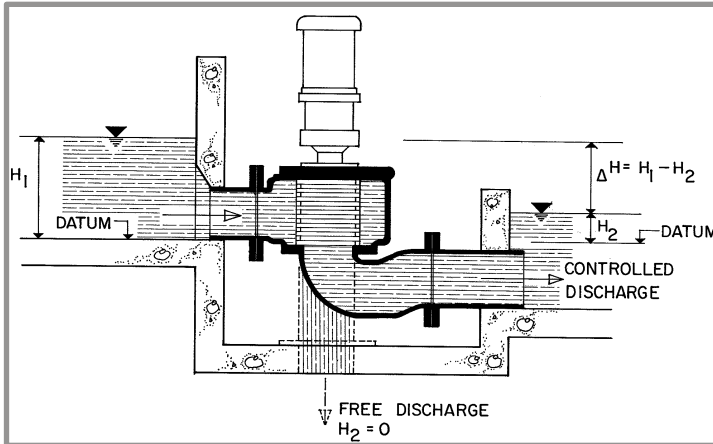

GENERAL DATA

Capacity	0-130 GPM (US)	0-8.2L/s
Drum Diam.	5.3 in	13.5 cm
Inlet Area	13 in ²	83.9 cm ²
Outlet Area	8 in ²	51.6 cm ²
Slot Width	0.470 in	12 mm

MODEL 5A - FREE DISCHARGE
MODEL 5B - CONTROLLED DISCHARGE WITH
 CAST IRON RETURN BEND
 PVC RETURN BEND

HYDRAULIC PERFORMANCE CURVE

Flow Rate Q - Cubic Meters Per Day x 10²

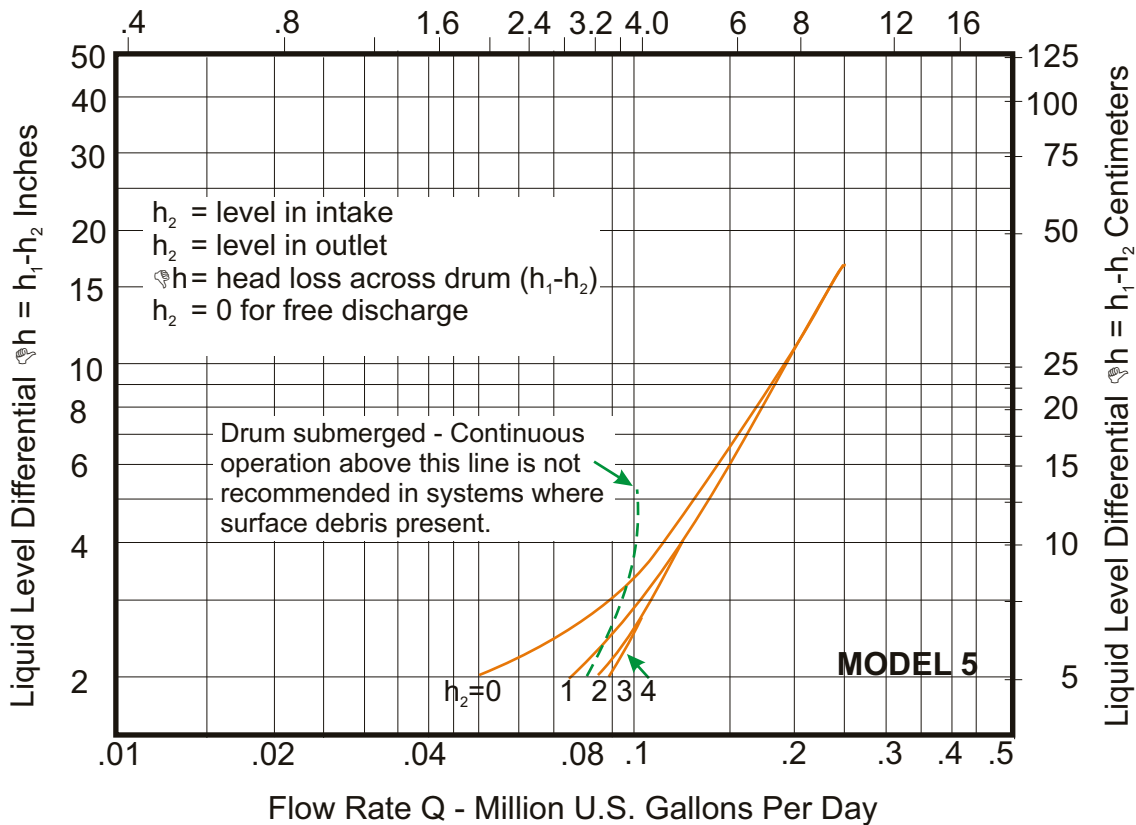

G.E.T. Industries Inc.

Toll Free: (877) 213-7418

E-mail: get@grindhog.com ♦ Web: www.grindhog.com



PIPE MOUNTED MODEL 5 cont'd...

DESIGN FEATURES

SM-CYCLO® SPEED REDUCERS

- HIGHEST OVERLOAD CAPACITY FOR FREQUENT STOP-START AND SEVERE REVERSING
- RELIABLE, MAINTENANCE-FREE SERVICE
- SMOOTH, SILENT OPERATION
- EXCEPTIONAL LIFE

Torque transmitting parts roll, don't grind. There is no sliding friction, so output torque/input horsepower efficiency approaches 95%.

SUBMERGED FASTENERS OF STAINLESS STEEL

HEAVY DUTY CAST IRON CONSTRUCTION

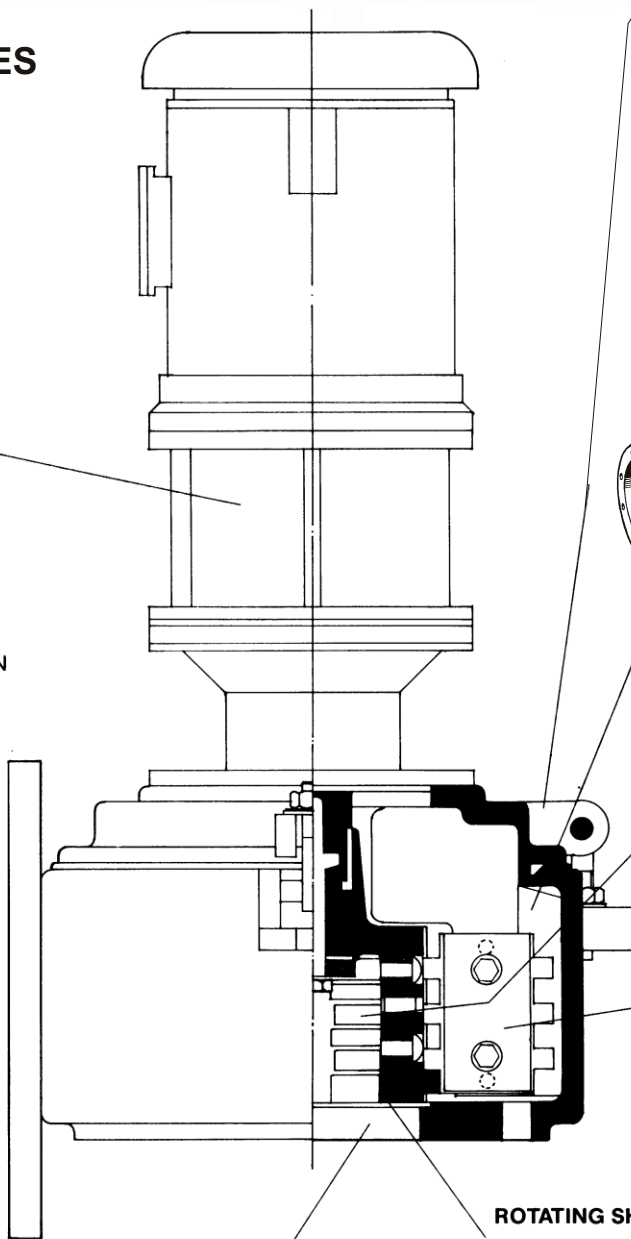

DISCHARGE OPTIONS

- FREE DISCHARGE TO TANK OR WET WELL
- CONTROLLED DISCHARGE — CAST IRON OR PVC RETURN BEND

HINGED MECHANISM

- EASE OF INSPECTION
- REVERSING CUTTING BAR SECURING COVER OF CASING FOR INSPECTION AND MAINTENANCE

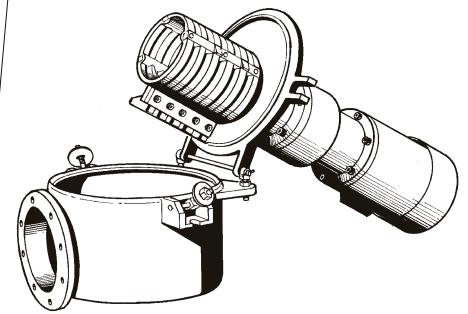

SEALED CHAMBER

- NEOPRENE "O" RING SEAL ALLOWS FOR SURCHARGED OPERATION

CAST DUCTILE IRON SEWAGE SCREEN

- LONG LIFE UNDER ABRASIVE CONDITIONS

STATIONARY CUTTING BAR

- REVERSIBLE-SPARE STANDARD EQUIPMENT
- A2 HIGH QUALITY TOOL STEEL
- HIGH RESISTANCE TO WEAR

ROTATING SHEAR BAR ASSEMBLY

- MACHINED FROM SOLID BARSTOCK
- PRECISE TOLERANCES MAINTAINED.

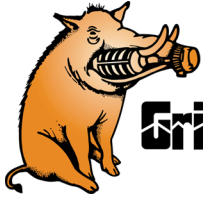

Grind Hog™

MECHANICAL DETAIL

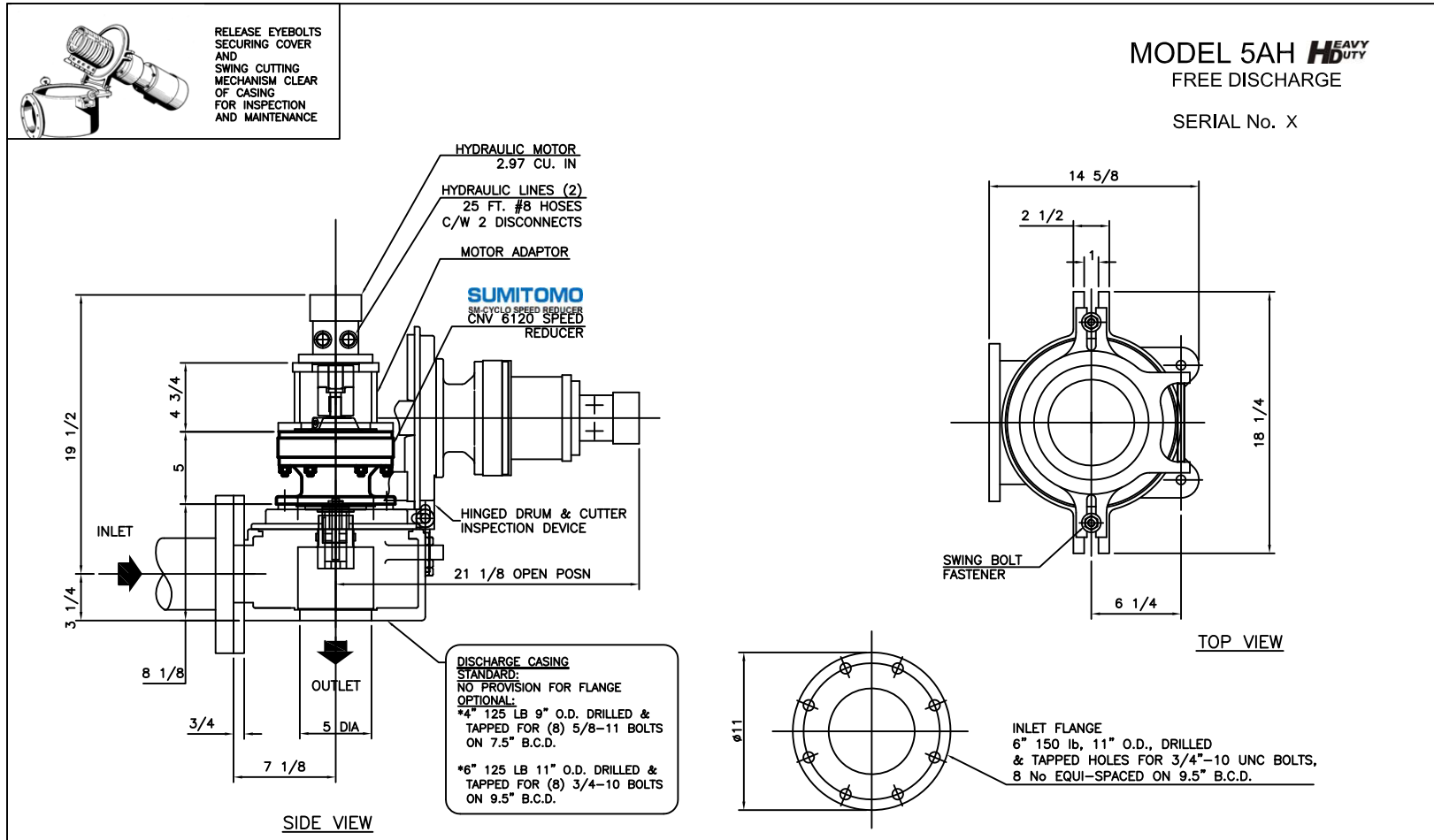

MATERIALS OF CONSTRUCTION & GENERAL ENGINEERING DATA													
HOUSING:	GREY IRON	CAPACITY	130 GPM (US) / 8.2 L/s	INLET AREA	13 SQ IN	83.9 cm sq							
DRUM (SCREEN):	DUCTILE IRON (ASTM 536 GRADE 60-45-18)	DRUM SPEED	50 RPM	OUTLET AREA	8 SQ IN	51.6 cm sq							
SHEAR BARS:	AISI-A2 HIGH ALLOY TOOL STEEL	ROTATION	C / CLOCKWISE	DRUM DIAMETER	5.3 IN	13.5 cm							
CUTTING BARS:	AISI-O1 TOOL STEEL REVERSIBLE	SLOT WIDTH	.470 IN / 12 mm	WEIGHT	170 LB	77 kg							
HARDWARE & FASTENERS:	304 STAINLESS STEEL	No. OF SLOTS	12										
MOTOR MANUFACTURER:	DANFOSS	POWER:	HYDRAULIC	RPM:	930 MAX	REDUCER:	SM - CYCLO	MODEL:	V6120				
STYLE:	DH50 - 2.97 CU IN	HP:	-	KW:	6.8 MAX	FRAME:	56C	FLANGE:	-	RATIO:	35:1	RATING:	4.27 HP

G.E.T. INDUSTRIES INC.
get@grindhog.com
www.grindhog.com
1 (877) 213-7418

TOLERANCES	INFO. INFO. INFO. INFO.	SCALE
DECIMAL		NTS
FRACTIONAL		DRAWN BY
ANGULAR		G.P.
DATE		APPROVED BY
JAN. 2015	W.D.M.	
FILE NO.	DRWG. No.	REV.
	6 0037	

Dimensional Detail